

SKF Waviness Analyzer

Measuring device for medium bearing rings and large rollers

MWA 250SA



General description

The MWA 250SA computer based analyzer covers all demands of modern quality control for roundness and waviness. To enable the analysis of small-tolerance fields in mechanical production, the MWA 250SA provides highest accuracy and resolution, not normally available on basic roundness measuring instruments. Possible measuring objects are medium bearing rings and large rollers.

Measuring capabilities

The MWA 250SA provides macro geometry measurements and analysis of:

- Roundness
- Harmonics
- Waviness
- Flatness

Rapid cycle times and flexibility

Simple and fast set-up and operation are ensured by the modular and powerful but user-friendly design of the hard- and software:

- A large number of specialized tools for performing serial measurements are available.
- Individual measuring sequences with an infinite number of evaluation criteria, each with its own tolerance values, are pre-programmable and can be stored for each part of the sample.
- This enables machine operators to perform detailed measurements and get immediate machine-settings and accept/reject decisions from the system without requiring any programming on their part.



- Repeat measurements can be summarized statistically on request, giving the mean (\bar{x}), standard deviation (s), range and histogram of each criterion used.

Close to the manufacturing

The design of the MWA 250SA has the measuring mechanics placed on a dampened steel plate. This allows the equipment to be used not only in standard measuring rooms or laboratories, but also right on the production floor – and that’s where modern quality assurance mainly takes place.

Powerful and user-friendly

Roundness and waviness measurements are the two principles traditionally used worldwide to qualify round parts. Each principle has advantages and disadvantages, depending on the requirements.

Machine description

For different test pieces and applications there are various measuring stands, sensors and chucks available. In the figure below you see one application.

- 1 Monitor
- 2 Air bearing spindle with centring table
- 3 Measuring electronics MEC 7001 A
- 4 Measuring stand with sensor holder
- 5 Measuring sensor
- 6 Pneumatics

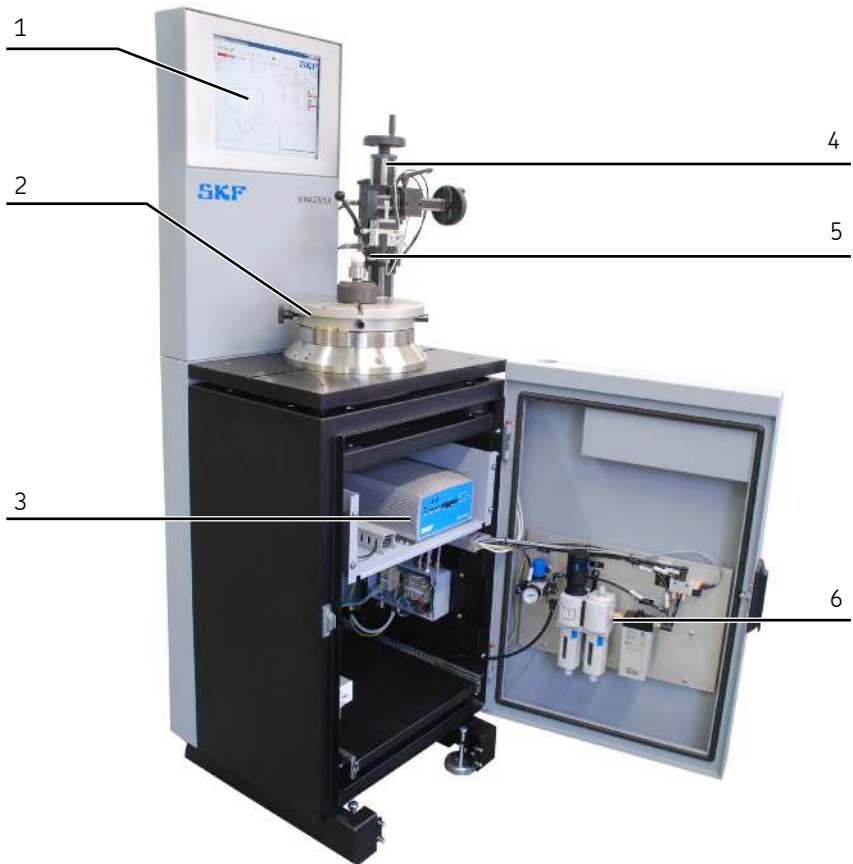

The MWA 250SA software allows both benefits to be utilized and provides an analysis of roundness as well as of waviness.

Additionally Fast Fourier Transformation (FFT) provides detailed harmonics analysis.

Waviness analysis

The MWA 250SA provides waviness evaluation as outlined below:

- Displacement-proportional readout (μm) corresponding to Bendix Waveometer machines (low Band and high Band)
- Vibration-velocity-proportional read-out ($\mu\text{m}/\text{sec}$), corresponding to SKF standard
- User-programmable waviness evaluation, by selecting any combination of
 - frequency band
 - velocity or displacement proportional read-out
 - r/min in the case of velocity proportional read-out.

Functional principle

The measuring object is placed into the chuck of the spindle which is then rotated manually. The probe is applied manually or pneumatically to the part. After performing the measurement,

the results are automatically checked for plausibility, presented on the monitor and then documented on an attached printer.

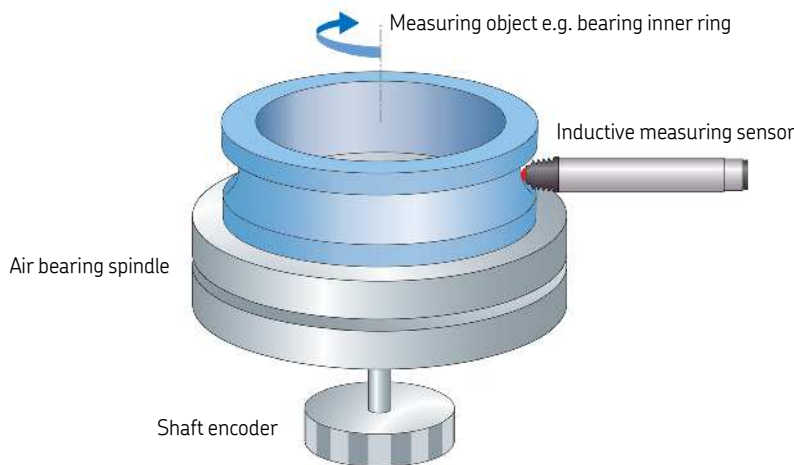

Technical specifications

- Mechanics
 - Working range:
 - Min. OD to max OD - rings: 90 to 250 mm (3.5 to 9.84 in.)
 - Min. bore: 90 mm (3.5 in.)
 - Min. OD - rollers: 20 mm (0.79 in.)
 - Max. height: 250 mm (9.84 in.)
 - Workpiece weight: Max. 100 kg (220 lbs)
 - Spindle: Vertical air bearing spindle
 - Spindle drive: Manual
 - Maximum spindle load: Axial 2 000 N (450 lbs) centrically
 - Paint: Silver-grey RAL 7001
- Electronics:
 - Measuring electronics: MEC 7001 A; for details see data sheet MEC 7001 A
 - Sensor: Various inductive measuring sensors available
 - Software: WinMWA, operating system Windows 10; for details see data sheet MEC 7001 A
- System accuracy:
 - Δr –Repeatability measured at 5 r/min spindle speed, optimum conditions and optimum work piece: $< 0,1 \mu\text{m}$ (4 $\mu\text{in.}$)
 - Waviness repeatability:
 - Up to 25 waves, $\leq 2 \mu\text{m/s}$
 - Above 25 waves, $\leq 15 \mu\text{m/s}$
- Dimensions and weights
 - Dimensions (H x W x D): 1 700 x 600 x 590 mm (66.9 x 23.6 x 23.2 in.)
 - Weight: Approx. 160 kg (353 lbs)
- Requirements:
 - Electrical system: See rating plate 230 V/50 Hz/500 VA, 115 V/60 Hz/500 VA,
 - Pneumatic system:
 - Air pressure 5 bar (72.5 psi) at least
 - Air consumption 3 Nm³/h
 - Air quality, instrument air = dry, filtered and oil free oil $< 0,01 \text{ mg/m}^3$, water pressure dew point = 2 °C
 - Temperature: Normal temperatures, Temperature gradient less than 1 degree/hour, no fan blowing on the equipment, no open doors near by which can increase the temperature gradient
 - Air humidity: Must not exceed 60% in summer and 70% in winter, if the relative humidity is higher, we recommend air-conditioning
 - Location: Install the machine on flat, firm ground; install the machine where it is not exposed to shocks (e.g. near forging machines, presses and the like), it should not be located on floors where you can easily feel vibrations with your legs.

Technical specifications subject to change without notice.

For more information on your specific application, please contact our engineers at QT.

Please contact:

SKF Österreich AG
Quality Technology

Seitenstettner Strasse 15 · A 4401 Steyr · Austria

Tel: +43 (0)7252 797-571 · Fax: +43 (0)7252 797-574 · Email: qt-steyr@skf.com

Web: www.skf.com/qt-steyr

© SKF is a registered trademark of the SKF Group.

Windows 7 is either a registered trademark or trademark of Microsoft Corporation in the United States and/or other countries.

© SKF Group 2019

The contents of this publication are the copyright of the publisher and may not be reproduced (even extracts) unless prior written permission is granted. Every care has been taken to ensure the accuracy of the information contained in this publication but no liability can be accepted for any loss or damage whether direct, indirect or consequential arising out of the use of the information contained herein. SKF reserves the right to alter any part of this publication without prior notice.

PUB CM/P2 14649/2 EN · May 2019

